

MARK	DATE	REVISION	REVISER	APP_BY
△	NOV.24.2021	Rev.1	Y.H.JANG	ZANGA
△				
△				

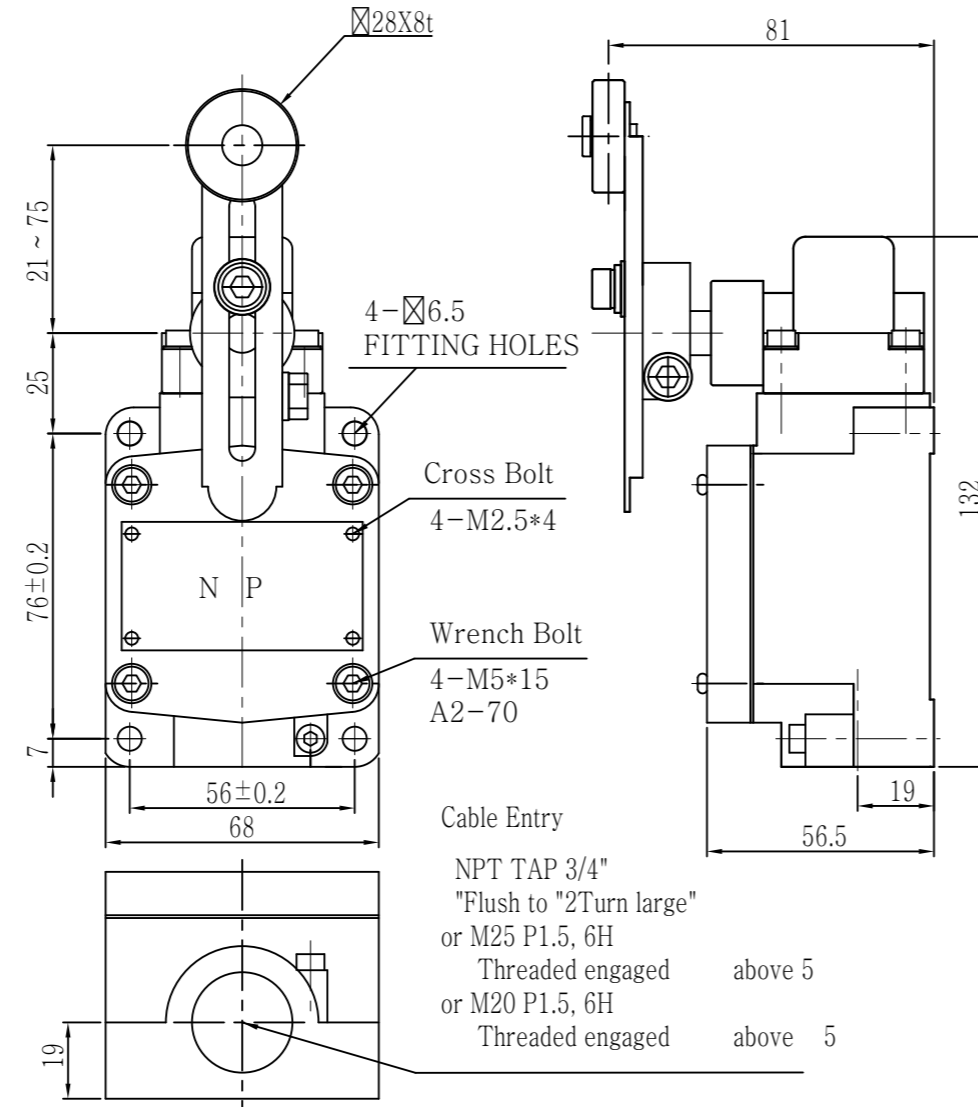

Model No.	LZ1710 - AL
Material	Head, Body & Cover Die cast Bs Bolt, Nut & Ect - SUS
Contact	2KCT-DB, 1A1B, VDC/A 14/10, 30/6, 125/0.8, 250/0.4 VAC/A 125/10, 250/6 & 480/2
Insulation Resistance	100M Ω Min. At 500V DC
Protection Grade	Explosion Proof : Ex db IIC T6 Gb Tamb : -55° C ~ 40° C
Cable Entry	NPT 3/4 or M25 or M20
Color	Maker standard
Surface resistance of the material	Below 1G Ω at (50 ± 5) % relative humidity

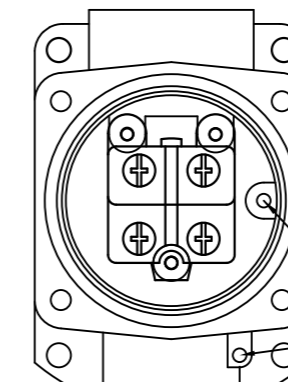

△ ⊕ Earth Point

- WRENCH BOLT : M4*6, SUS 304
- CONECT TERMINAL :
I.D $\varnothing 4.2$, O-TYPE, MAT'L C5212
- EARTH LINE : Above 4mm²

	LZ1710-S001	LZ1710-AL	Bs & ect	1	-
Nr.	DWG. NO.	TITLE/ NAME	MAT'L	QTY	REFERENCE
DSND BY	CHKD BY	CHKD BY	APRV BY	VIEW	DATE
Y.H.JANG	-	ZZANGA	-	3	OCT. 10. 2019
TITLE					SCALE
AL TYPE OUT DWG.					1/1
SYE.C For Mairne, Heavy Duty & Exp. L/S LZ1710					
DWG. Nr.			EDITION	SHEET	
LZ1710-S001			1	1/1	